

- Notes:
- CONTROL PANEL, (OPTIONAL BATTERY CHARGER INSIDE).
 - 120V, 20A GFCI & 250V, 15A OUTLET (OPTIONAL).
 - CONNECTION POINTS FOR CONTROL WIRES PROVIDED IN THE LOW VOLTAGE CONNECTION BOX (USE LOW VOLTAGE STUB-UP AREA).
 - BATTERY (12 VOLT NEGATIVE GROUND SYSTEM).
 - MAIN LINE CIRCUIT BREAKER (MLCB), AC LOAD LEADS. (DIMENSIONS MAY VARY DUE TO UNIT CONFIGURATION)
 - CENTER OF GRAVITY AND WEIGHT MAY CHANGE DUE TO UNIT OPTIONS.
 - ENGINE SERVICE CONNECTIONS:
 INLET NATURAL GAS = 1-1/4" FEMALE NPT COUPLING
 INLET DIESEL = N/A
 RETURN DIESEL = N/A
 OIL DRAIN = 1/2" NPT FEMALE COUPLING
 RADIATOR DRAIN = 1/2" NPT FEMAL COUPLING
 FLEX PIPE OUTLET = 2.5" I.D.
 EXHAUST OUTLET = 2.5" O.D.
 ***** SEE GENERATOR SIZING GUIDE FOR FUEL PIPE SIZING TO SUIT APPLICATION *****

- AUXILIARY AC CONNECTION FOR UNIT OPTIONS ARE LOCATED IN HIGH VOLTAGE CONNECTION BOX, UNLESS AN OPTIONAL LOAD CENTER IS INSTALLED.
 - EXHAUST PIPES MAY BE ROTATED TO ALLOW MUFFLER TO POINT OUT TO THE RIGHT OR LEFT SIDE OF GENERATOR. (MAY NOT APPLY TO ALL UNITS)
 - GENERATOR SET MUST BE INSTALLED SUCH THAT FRESH COOLING AIR IS AVAILABLE AND DISCHARGE AIR FROM THE RADIATOR IS NOT RECIRCULATED.
 - BOTTOM OF GENERATOR SET MUST BE ENCLOSED TO PREVENT PEST INTRUSION AND RECIRCULATION OF DISCHARGE AIR AND/OR IMPROPER COOLING AIR FLOW.
 - EXHAUST SYSTEM MAXIMUM BACK PRESSURE = 37 INCHES H2O.
 - INSTALL EXHAUST BLANKETS ALONG THIS LINE.
 - CONNECT THE OPEN SET EXHAUST PER NFPA 37
 - BLANKETS SHOULD NOT COVER OXYGEN SENSOR.
 - OXYGEN SENSOR MUST BE MOUNTED BETWEEN ENGINE OUTLET AND SILENCER INLET AS SHOWN. IF ELBOW IS REQUIRED, ONLY SINGLE ELBOW MAY BE USED.
 - CATALYZED SILENCER (FOR EPA UNITS) MUST BE MOUNTED IN DESCRIBED POSITION. FAILING TO FOLLOW THESE INSTRUCTIONS WHEN INSTALLING A CERTIFIED ENGINE IN A PIECE OF STATIONARY EQUIPMENT VIOLATES FEDERAL LAW 40 CFR 1068.105(b), SUBJECT TO FINES OR PENALTIES AS DESCRIBED IN THE CLEAN AIR ACT.
 - BOLTS OR STUDS USED TO MOUNT UNIT TO PAD SHALL BE 5/8 - 11 GRADE 5.
- ADDITIONAL NOTES: FOR WEIGHT AND CENTER OF GRAVITY DATA SEE NOTE 6, AND SHEET 3.

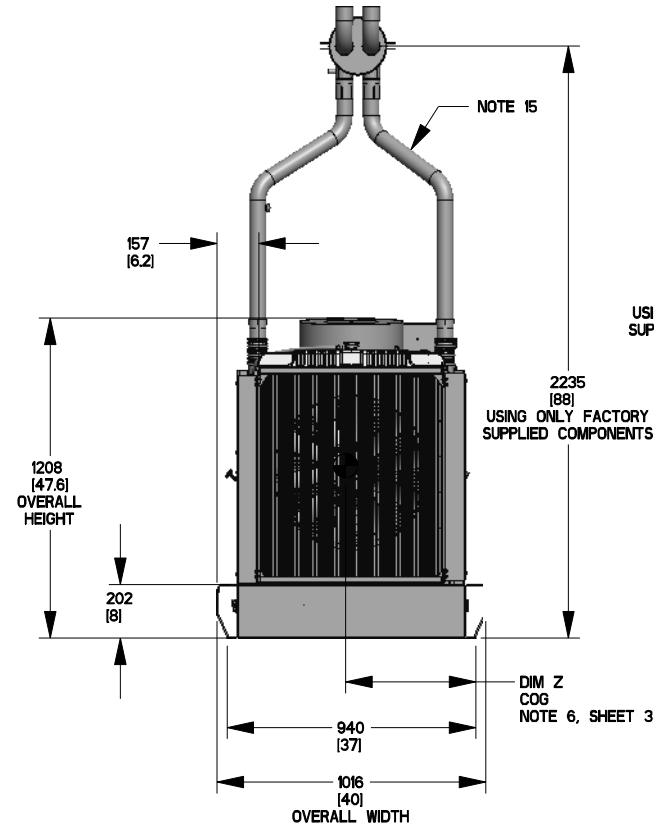
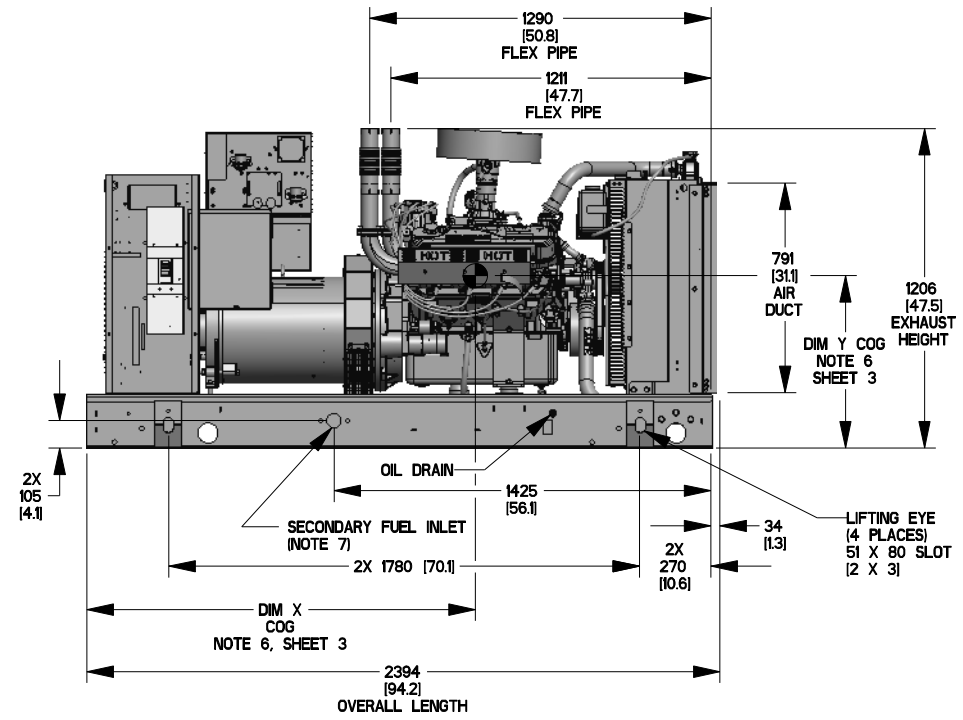
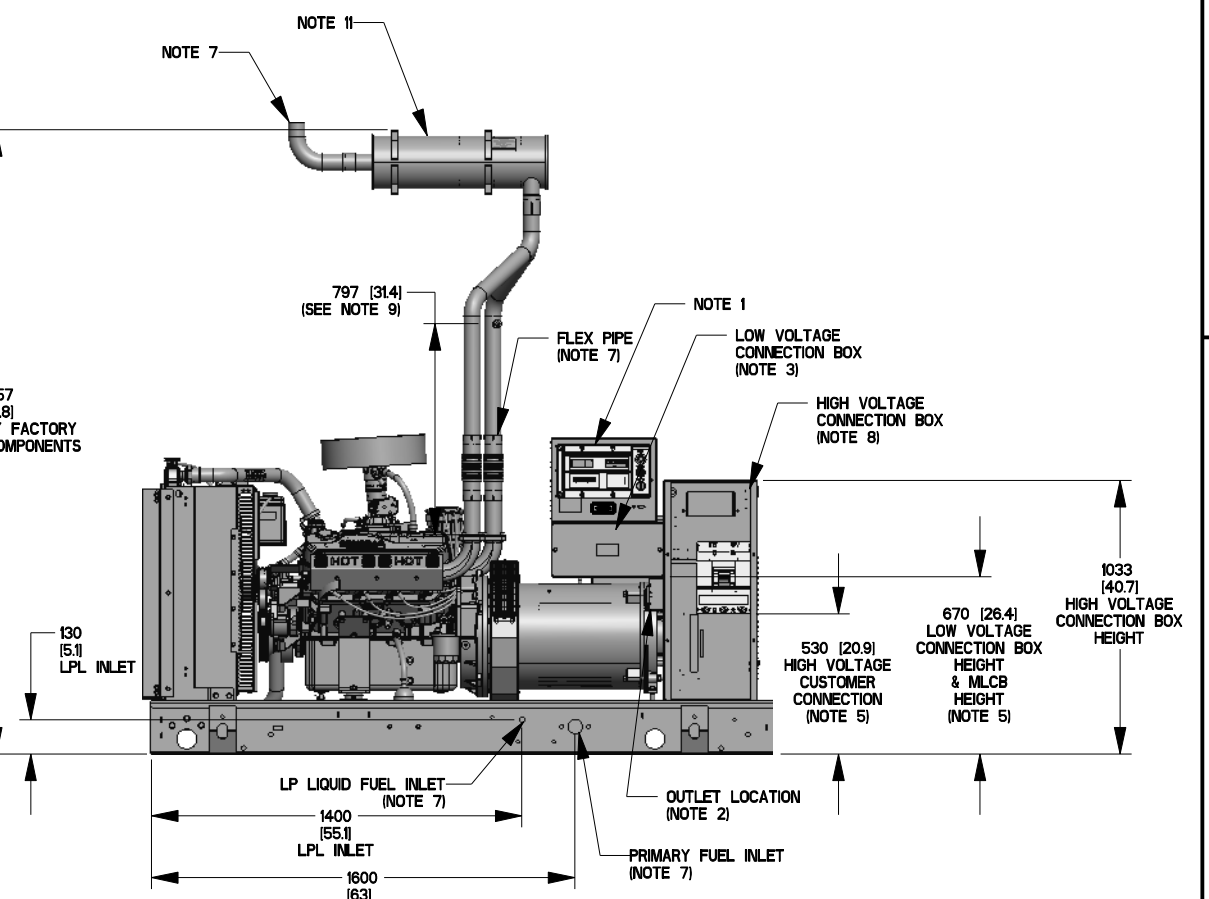
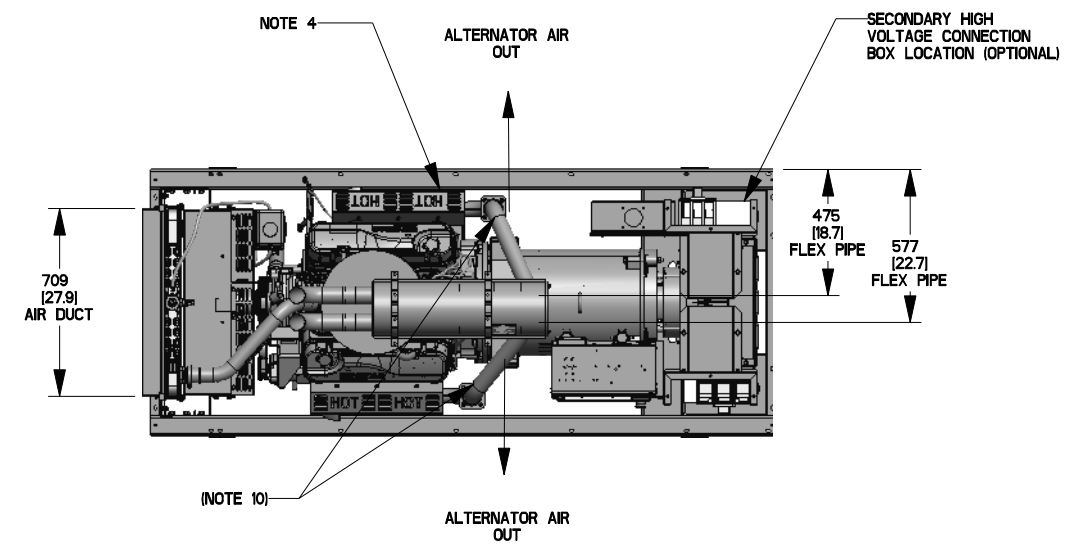

DIMENSIONS ARE IN MILLIMETERS (INCHES)

DRAWING CREATED FROM PRO/ENGINEER 3D FILE. ECO MODIFICATION TO BE APPLIED TO SOLID MODEL ONLY.

INSTALLATION DRAWING

GENERAC POWER SYSTEMS OWNS THE COPYRIGHT OF THIS DRAWING WHICH IS SUPPLIED IN CONFIDENCE AND MUST NOT BE USED FOR ANY PURPOSE OTHER THAN FOR WHICH IT IS SUPPLIED WITHOUT THE EXPRESS WRITTEN CONSENT OF GENERAC POWER SYSTEMS. © GENERAC POWER SYSTEMS 2012

ELECTRONICALLY APPROVED INSIDE WINDCHILL



TITLE
 OPEN SET
 G8.0L, 60HZ: SG080, PG072 50HZ: SG064, PG058
 G9.0L, 60HZ: SG100, PG090 50HZ: SG080, PG072

ISSUE DATE: 07/25/14		REV F-1	
SIZE B	CAGE NO N/A	DWG NO OK0383	REV F-1
SCALE 0.035	WT-KG	SHEET 1 of 3	

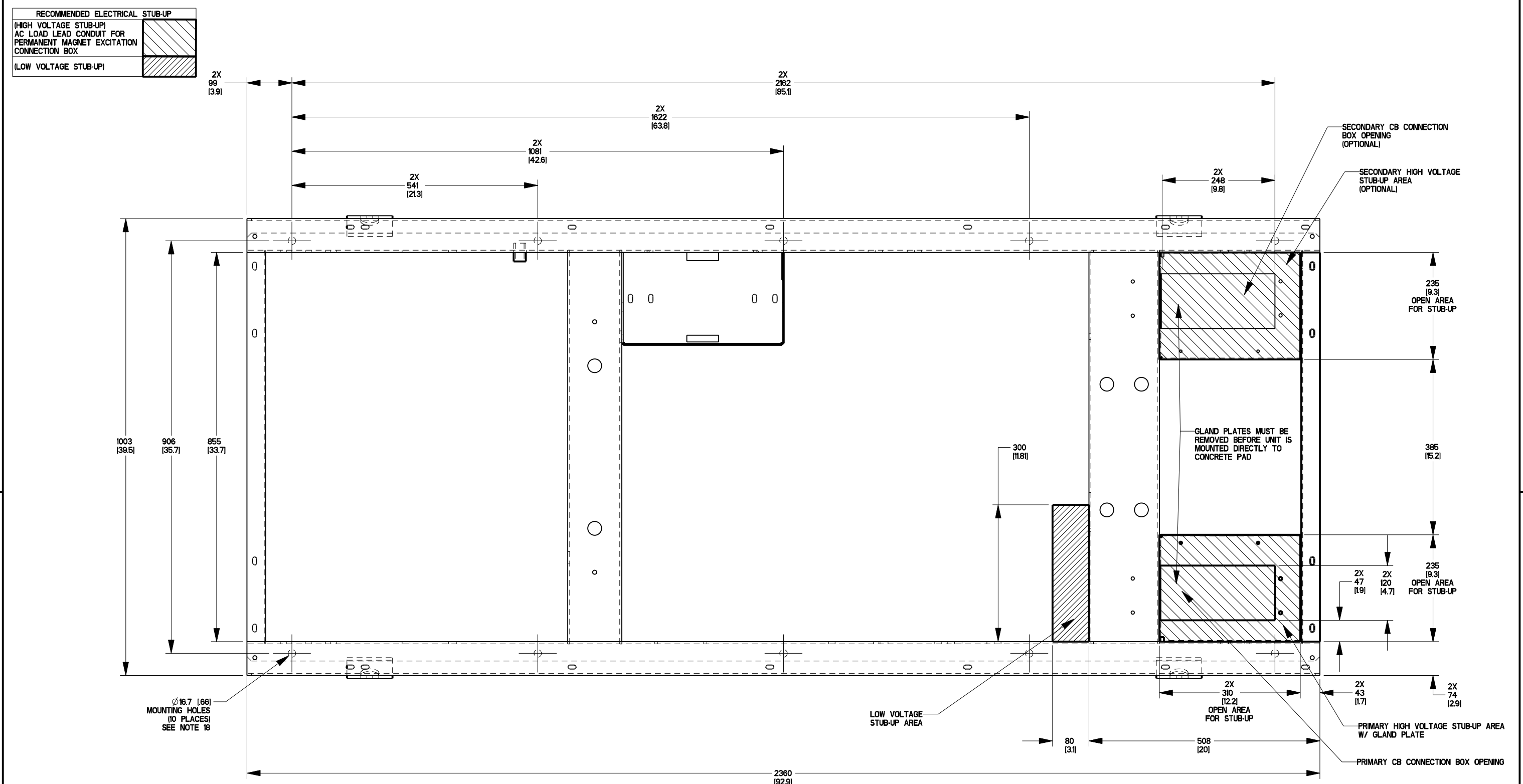

DRAWING CREATED FROM PRO/ENGINEER 3D FILE. ECO MODIFICATION TO BE APPLIED TO SOLID MODEL ONLY.

DIMENSIONS ARE IN MILLIMETERS (INCHES)



TITLE
STUB-UP VIEW
 G8.0L, 60HZ: SG080, PG072 50HZ: SG064, PG058
 G9.0L, 60HZ: SG100, PG090 50HZ: SG080, PG072

ISSUE DATE: 07/25/14		REV F-1	
SIZE B	CAGE NO N/A	DWG NO OK0383	REV F-1
SCALE 0.120	WT-KG	SHEET 2 of 3	

INSTALLATION DRAWING

GENERAC POWER SYSTEMS OWNS THE COPYRIGHT OF THIS DRAWING WHICH IS SUPPLIED IN CONFIDENCE AND MUST NOT BE USED FOR ANY PURPOSE OTHER THAN FOR WHICH IT IS SUPPLIED WITHOUT THE EXPRESS WRITTEN CONSENT OF GENERAC POWER SYSTEMS. © GENERAC POWER SYSTEMS 2012

ELECTRONICALLY APPROVED
 INSIDE WINDCHILL

OPEN SET

MODEL	VOLTAGE	WEIGHT	CENTER OF GRAVITY DIM X	CENTER OF GRAVITY DIM Y	CENTER OF GRAVITY DIM Z
SG 080/064, PG 072/058	220V, 240V, 1Ø	1,018 kg [2,245 lbs]	1308 [51.5]	509 [20.1]	466 [18.3]
SG 064/080/100, PG 058/072/090	220V, 240V, 1Ø (100kw)	1,068 kg [2,355 lbs]	1275 [50.2]	506 [19.9]	
SG 080/100, PG 090/072	220V, 240V, 1Ø (130kw UPSIZED)	1,132 kg [2,496 lbs]	1229 [48.4]	502 [19.8]	
SG 080/064, PG 072/058	208V, 240V, 400V, 480V, & 600V	1,023 kg [2,256 lbs]	1305 [51.4]	509 [20.0]	
SG 064/080/100, PG 058/072/090	208V, 240V, 400V, 480V, & 600V (100kw)	1,075 kg [2,371 lbs]	1271 [50.1]	506 [19.9]	
SG 080/100, PG 090/072	208V, 240V, 400V, 480V, & 600V (130kw UPSIZED)	1,153 kg [2,543 lbs]	1218 [47.9]	501 [19.7]	

NOTE: CENTER OF GRAVITY AND WEIGHT MAY CHANGE DUE TO UNIT OPTIONS.

STD ENCLOSURE, STEEL

MODEL	VOLTAGE	WEIGHT	CENTER OF GRAVITY DIM X	CENTER OF GRAVITY DIM Y	CENTER OF GRAVITY DIM Z
SG 080/064, PG 072/058	220V, 240V, 1Ø	1,258 kg [2,774 lbs]	1343 [52.9]	577 [22.7]	444 [17.5]
SG 064/080/100, PG 058/072/090	220V, 240V, 1Ø (100kw)	1,308 kg [2,884 lbs]	1315 [51.8]	572 [22.5]	
SG 080/100, PG 090/072	220V, 240V, 1Ø (130kw UPSIZED)	1,372 kg [3,025 lbs]	1275 [50.2]	566 [22.3]	
SG 080/064, PG 072/058	208V, 240V, 400V, 480V, & 600V	1,263 kg [2,785 lbs]	1341 [52.8]	577 [22.7]	
SG 064/080/100, PG 058/072/090	208V, 240V, 400V, 480V, & 600V (100kw)	1,315 kg [2,900 lbs]	1312 [51.6]	571 [22.5]	
SG 080/100, PG 090/072	208V, 240V, 400V, 480V, & 600V (130kw UPSIZED)	1,393 kg [3,072 lbs]	1266 [49.8]	564 [22.2]	

STD ENCLOSURE, ALUMINUM

WEIGHT	CENTER OF GRAVITY DIM "X"	CENTER OF GRAVITY DIM "Y"	CENTER OF GRAVITY DIM "Z"
1,136 kg [2,504 lbs]	1338 [52.7]	547 [21.5]	500 [19.7]
1,186 kg [2,615 lbs]	1307 [51.5]	543 [21.4]	
1,250 kg [2,756 lbs]	1264 [49.8]	538 [21.2]	
1,141 kg [2,515 lbs]	1335 [52.6]	547 [21.5]	
1,193 kg [2,630 lbs]	1304 [51.3]	542 [21.3]	
1,271 kg [2,802 lbs]	1253 [49.3]	536 [21.1]	

L1A ENCLOSURE, STEEL

MODEL	VOLTAGE	WEIGHT	CENTER OF GRAVITY DIM X	CENTER OF GRAVITY DIM Y	CENTER OF GRAVITY DIM Z
SG 080/064, PG 072/058	220V, 240V, 1Ø	1,331 kg [2,935 lbs]	1283 [50.5]	591 [23.3]	445 [17.5]
SG 064/080/100, PG 058/072/090	220V, 240V, 1Ø (100kw)	1,381 kg [3,045 lbs]	1259 [49.6]	585 [23.0]	
SG 080/100, PG 090/072	220V, 240V, 1Ø (130kw UPSIZED)	1,445 kg [3,186 lbs]	1224 [48.2]	579 [22.8]	
SG 080/064, PG 072/058	208V, 240V, 400V, 480V, & 600V	1,336 kg [2,946 lbs]	1281 [50.4]	590 [23.2]	
SG 064/080/100, PG 058/072/090	208V, 240V, 400V, 480V, & 600V (100kw)	1,388 kg [3,061 lbs]	1256 [49.4]	585 [23.0]	
SG 080/100, PG 090/072	208V, 240V, 400V, 480V, & 600V (130kw UPSIZED)	1,466 kg [3,233 lbs]	1215 [47.9]	577 [22.7]	

L1A ENCLOSURE, ALUMINUM

WEIGHT	CENTER OF GRAVITY DIM "X"	CENTER OF GRAVITY DIM "Y"	CENTER OF GRAVITY DIM "Z"
1,168 kg [2,630 lbs]	1308 [51.5]	555 [21.9]	440 [17.3]
1,218 kg [2,685 lbs]	1280 [50.4]	550 [21.7]	
1,282 kg [2,826 lbs]	1239 [48.8]	545 [21.5]	
1,173 kg [2,586 lbs]	1306 [51.4]	555 [21.9]	
1,225 kg [2,701 lbs]	1276 [50.2]	550 [21.7]	
1,303 kg [2,873 lbs]	1229 [48.4]	543 [21.4]	

L2A ENCLOSURE, STEEL

MODEL	VOLTAGE	WEIGHT	CENTER OF GRAVITY DIM X	CENTER OF GRAVITY DIM Y	CENTER OF GRAVITY DIM Z
SG 080/064, PG 072/058	220V, 240V, 1Ø	1,389 kg [3,062 lbs]	1366 [53.8]	665 [26.2]	443 [17.4]
SG 064/080/100, PG 058/072/090	220V, 240V, 1Ø (100kw)	1,439 kg [3,172 lbs]	1340 [52.8]	657 [24.7]	
SG 080/100, PG 090/072	220V, 240V, 1Ø (130kw UPSIZED)	1,503 kg [3,314 lbs]	1303 [51.3]	648 [25.5]	
SG 080/064, PG 072/058	208V, 240V, 400V, 480V, & 600V	1,394 kg [3,073 lbs]	1364 [53.7]	664 [26.1]	
SG 064/080/100, PG 058/072/090	208V, 240V, 400V, 480V, & 600V (100kw)	1,446 kg [3,188 lbs]	1337 [52.6]	656 [25.8]	
SG 080/100, PG 090/072	208V, 240V, 400V, 480V, & 600V (130kw UPSIZED)	1,524 kg [3,360 lbs]	1294 [50.9]	645 [25.4]	

L2A ENCLOSURE, ALUMINUM

WEIGHT	CENTER OF GRAVITY DIM "X"	CENTER OF GRAVITY DIM "Y"	CENTER OF GRAVITY DIM "Z"
1,193 kg [2,630 lbs]	1308 [51.5]	594 [23.4]	439 [17.3]
1,243 kg [2,740 lbs]	1280 [50.4]	587 [23.1]	
1,307 kg [2,881 lbs]	1239 [48.8]	580 [22.8]	
1,198 kg [2,641 lbs]	1306 [51.4]	593 [23.3]	
1,250 kg [2,756 lbs]	1276 [50.2]	586 [23.1]	
1,328 kg [2,928 lbs]	1229 [48.4]	577 [22.7]	

DRAWING CREATED FROM PRO/ENGINEER 3D FILE. ECO MODIFICATION TO BE APPLIED TO SOLID MODEL ONLY.

DIMENSIONS ARE IN MILLIMETERS (INCHES)



TITLE WEIGHT & CENTER OF GRAVITY G8.0L 60 HZ: SG080, PG072 50HZ: SG064, PG058 G9.0L, 60HZ: SG100, PG090 50HZ: SG080, PG072

ISSUE DATE: 07/25/14 SIZE B CAGE NO N/A DWG NO OK0383 REV F-1 SCALE 0.035 WT-KG SHEET 3 of 3

GENERAC POWER SYSTEMS OWNS THE COPYRIGHT OF THIS DRAWING WHICH IS SUPPLIED IN CONFIDENCE AND MUST NOT BE USED FOR ANY PURPOSE OTHER THAN FOR WHICH IT IS SUPPLIED WITHOUT THE EXPRESS WRITTEN CONSENT OF GENERAC POWER SYSTEMS. © GENERAC POWER SYSTEMS 2012

ELECTRONICALLY APPROVED INSIDE WINDCHILL

INSTALLATION DRAWING