

8

7

6

5

4

3

1

MOUNTING TO CONCRETE PAD

HOLE LOCATIONS FOR
OPTIONAL MOUNTING TO
A CONCRETE PAD

16.0 [5/8] DIA. CLEARANCE
HOLE (3) PLACES.
3/8 DIA. MASONARY ANCHOR
BOLTS RECOMMENDED

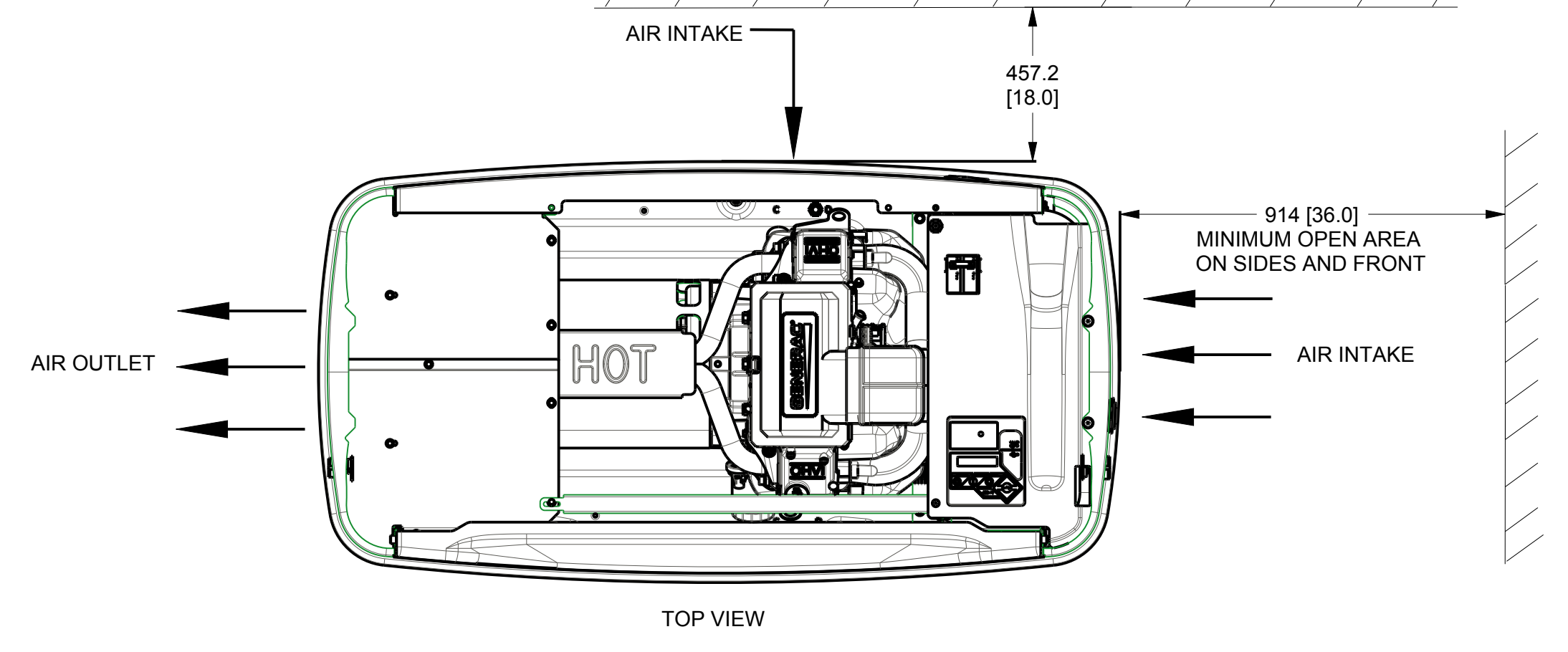
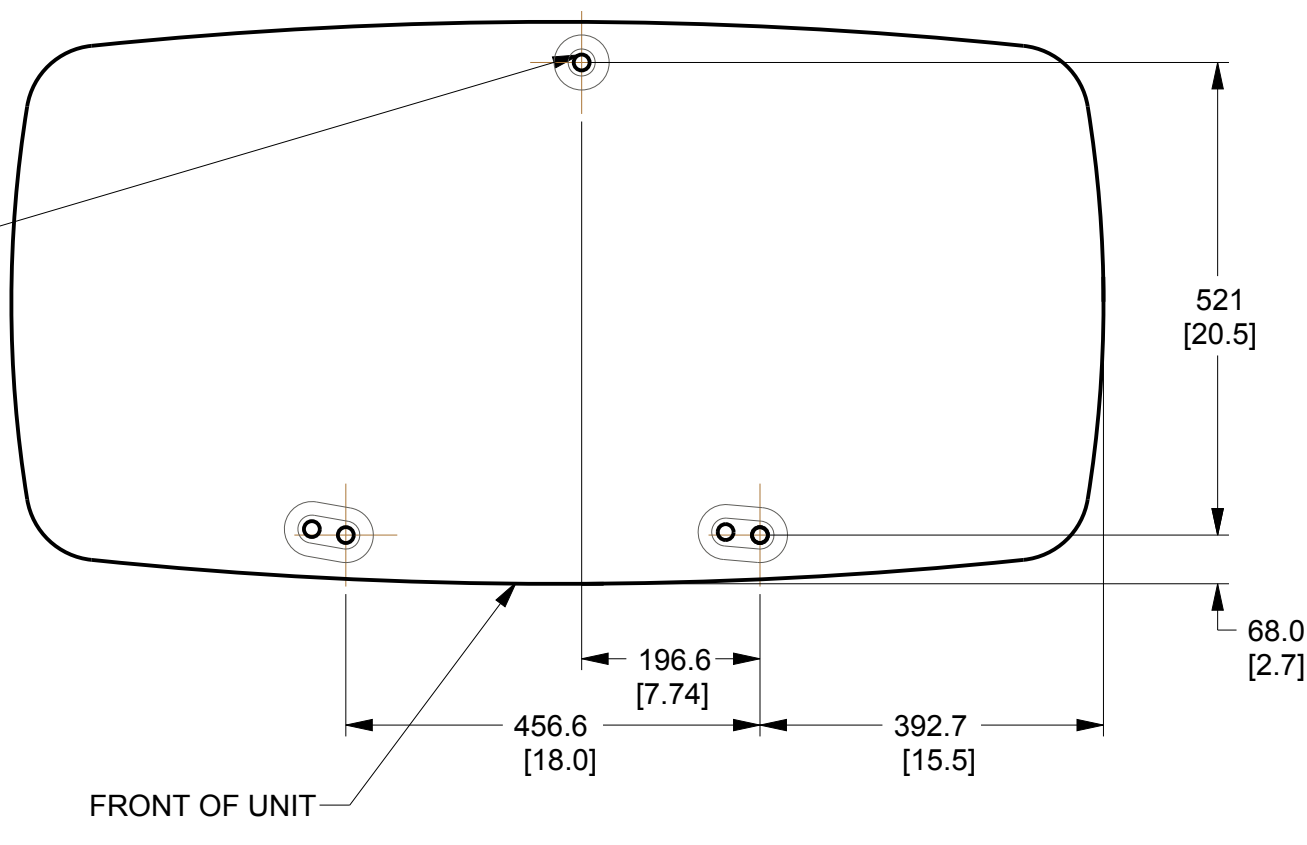

"DO NOT LIFT BY ROOF"

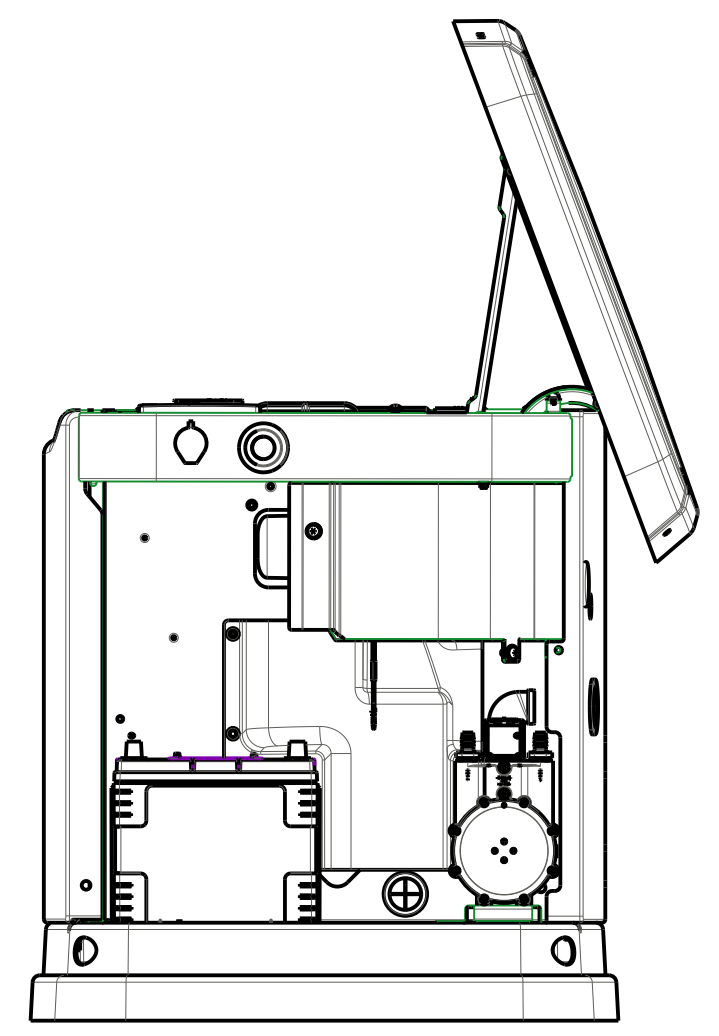
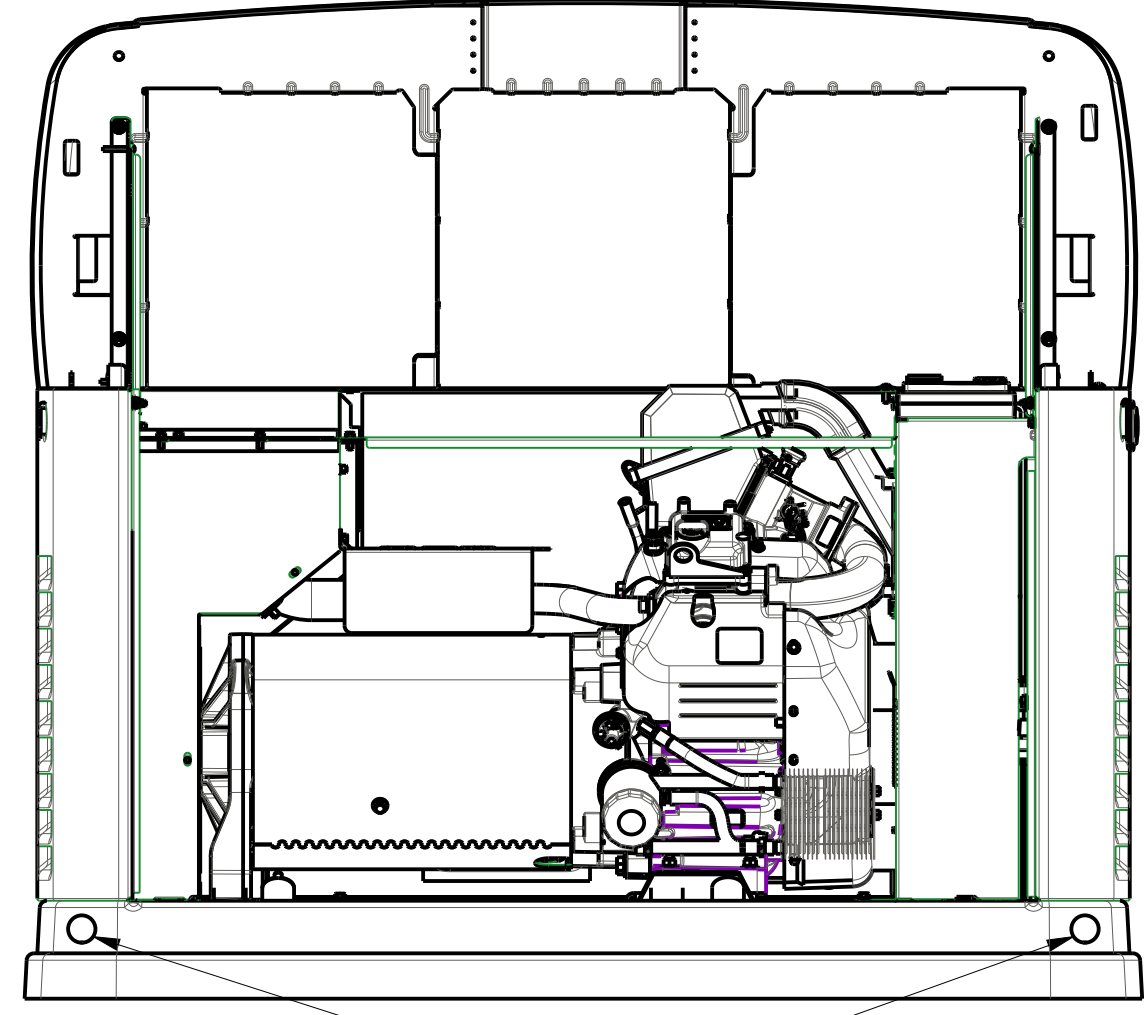

RIGHT VIEW
INTAKE PANEL REMOVED

MAIN AC/CONTROL WIRING HOLE FOR 1 1/4" CONDUIT

MAIN AC/CONTROL WIRING HOLE FOR 3/4" CONDUIT

FUEL INLET : 1/2" NPT (9-16kW)(8-13kVa)
: 3/4" NPT (20-22kW)

REQUIRED FUEL PRESSURE : NATURAL GAS : 3.5-7" WATER COLUMN
LIQUID PROPANE (VAPOR) : 10-12" WATER COLUMN

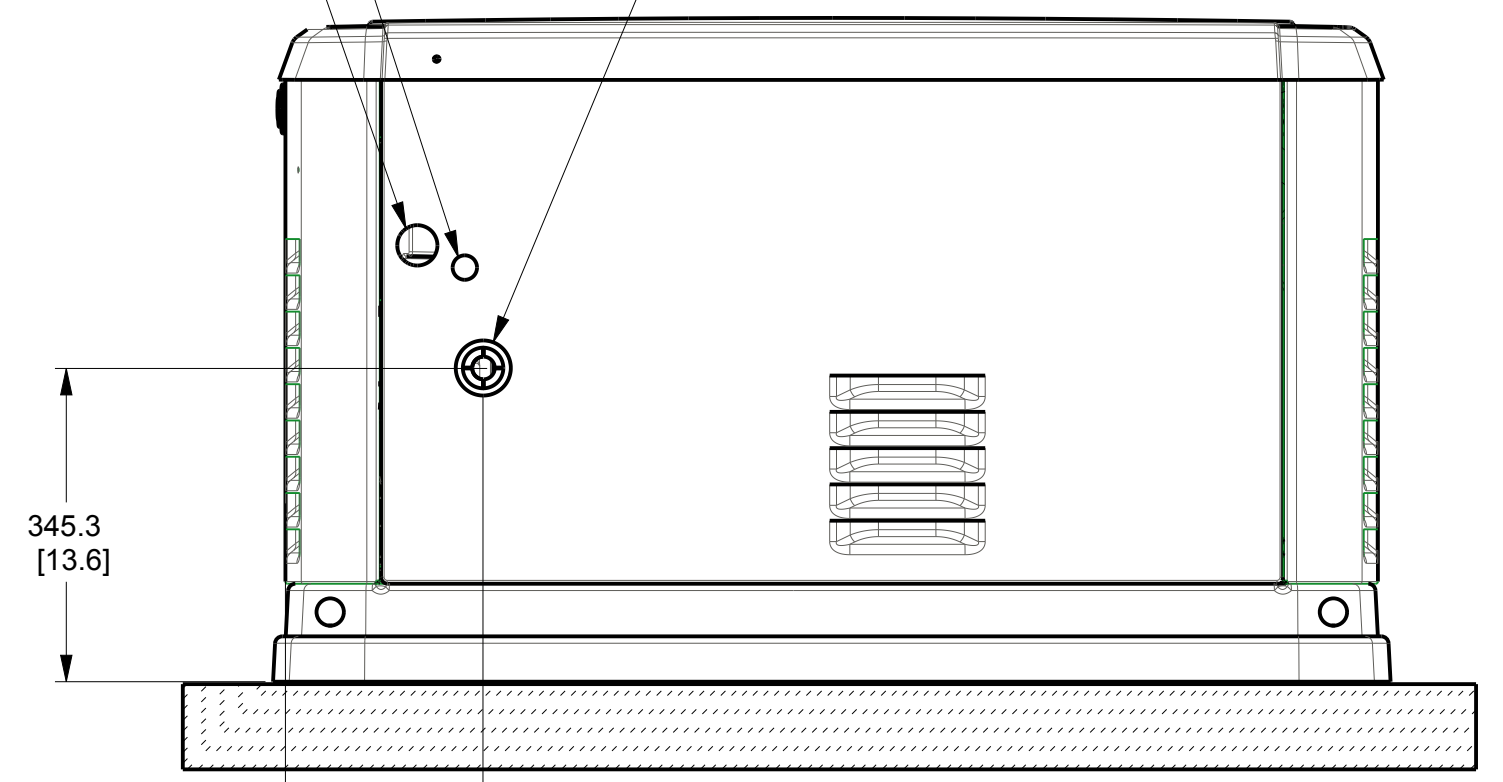

REAR VIEW

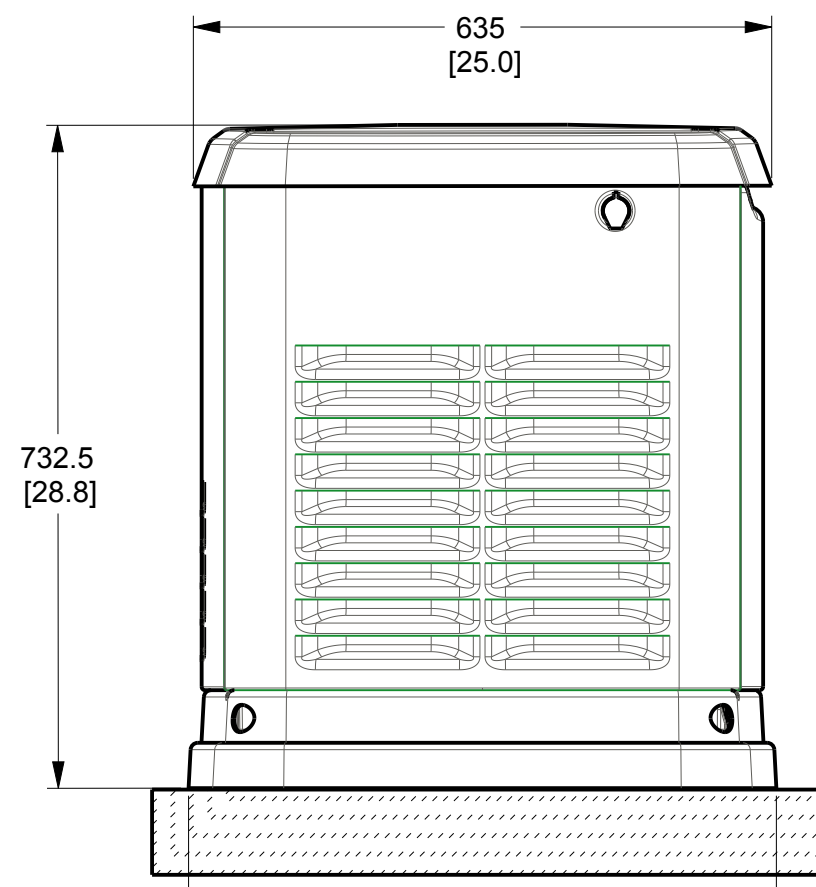

LEFT SIDE VIEW

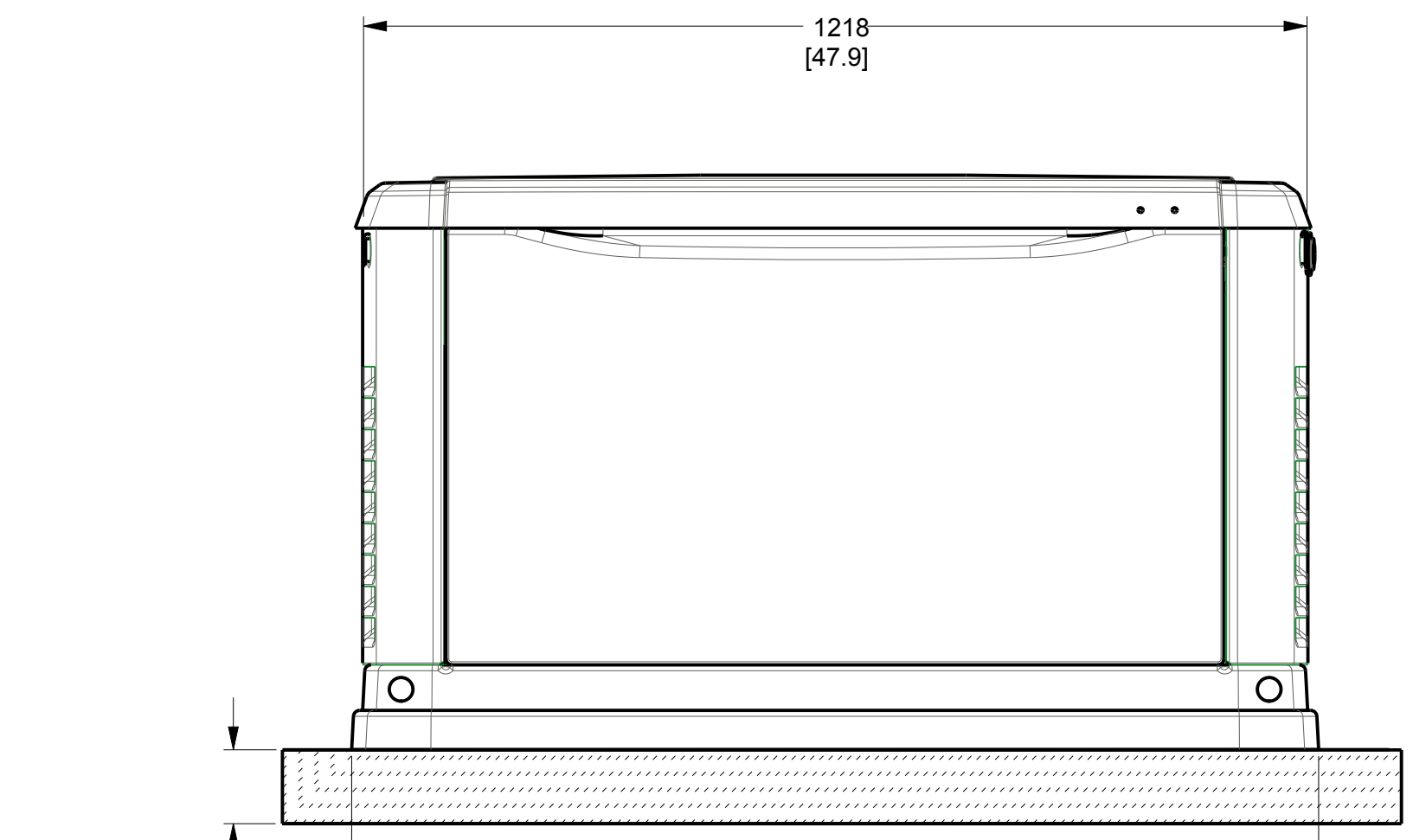

FRONT VIEW

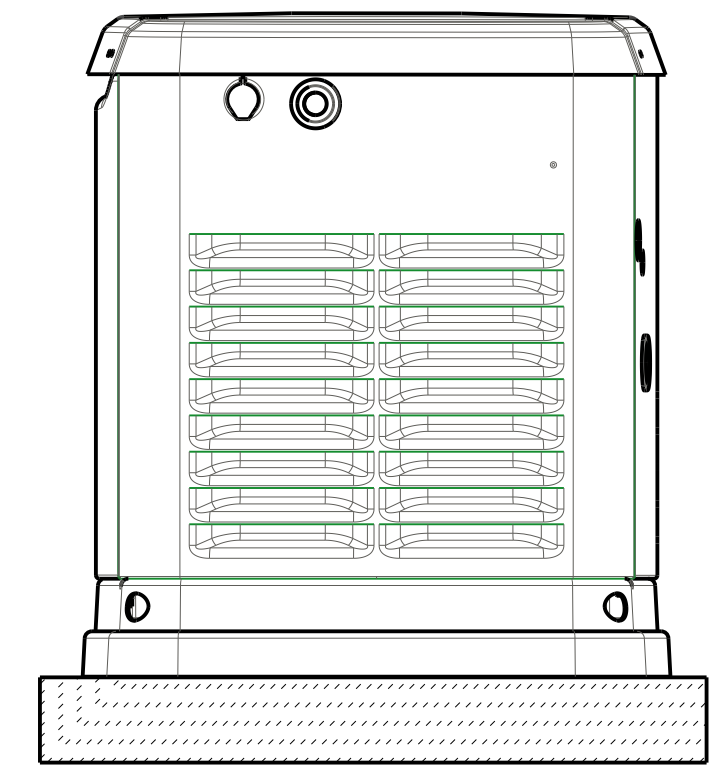

RIGHT SIDE VIEW

DRAWING CREATED FROM PRO/ENGINEER
3D FILE. ECO MODIFICATION TO BE
APPLIED TO SOLID MODEL ONLY.

ALL DIMENSIONS IN:
MILLIMETERS [INCHES]

INSTALLATION DRAWING

GENERAC					
TITLE INSTALL HSB GENERATOR NO T/SW					
G0070430					
ISSUE DATE:	03/18/2016				
SIZE	CAGE NO	DWG NO	REV		
B	N/A	10000002489	B		
SCALE	NTS	WT-KG	N/A	SHEET	1 of 1

8

7

6

5

4

3

2

1